



Грязеуловители в горшковом исполнении с фланцевым присоединением Ру 6 до Ру 40. или с концами под приварку.

Корпус сварной. Конструктивная длина по DIN EN 558-1 GR 1, начиная с Дн 250 DIN EN 558-1 GR 48. Комплект фильтровальный включает: опорную стабильную раму из перфорированной стали и сетку из стали специальной (1.4401) с размером ячеек около 0,96 мм . Свободное проходное сечение сетки соответствует $1,5 \times \frac{Dn^2}{4}$.

Пробка для выпуска воздуха в крышке грязеуловителя и пробка для опорожнения в нижней точке корпуса. Размеры фланцевых присоединений и отверстий по DIN 2501, уплотняющих поверхностей по DIN 2526 Form C. По запросу также по ГОСТ.

Strainer in pot-design with flange connection PN 6 up to PN 40

by request with welding ends acc. to DIN 3239.

Body in welded construction.

Face to face dimensions acc. to DIN EN 558-1 series 1, at DN 250 acc. to DIN EN 558-1 series 48.

Screen insert with solid screen cover made of perforated steel plate and insert stainless steel wire cloth, mesh size approx. 0,96 mm, material-no. 1.4401. The free screen area corresponds approx. the 1,5-fold connection cross section.

Vent plug in the sealing cover and drain plug in the bottom of the body.

Flange connection measured and drilled acc. to DIN 2501, sealing surface acc. to DIN 2526 form C.

Зак.-№ Order no.	Ру PN	Материал / Material						
		Корпус / Body		Крышка / Cover	Рама сетки / Screen frame	Сетка / Wire cloth		
SF 341	6	P235G1TH	1.0305					
SF 342	10	(St35.8)						
SF 343	16	C22G2	1.0460	P265GH	1.0425	S235JRG2	1.0038	X4CrNiMo17-12-2
SF 344	25	(C22.8)		(HII)		(RSt 37-2)		1.4401
SF 345	40	P265GH	1.0425					
SF 346	10	(HII)						
SF 347	16	X6CrNiMoTi17-12-2		X6CrNiMoTi17-12-2		X6CrNiMoTi17-12-2		X4CrNiMo17-12-2
SF 348	25		1.4571		1.4571		1.4571	1.4401



Исполнение Дн 50 150
Design DN 50 - 150

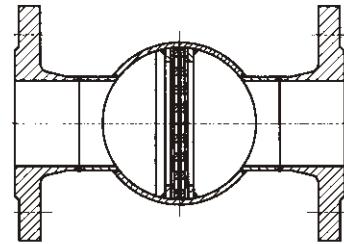
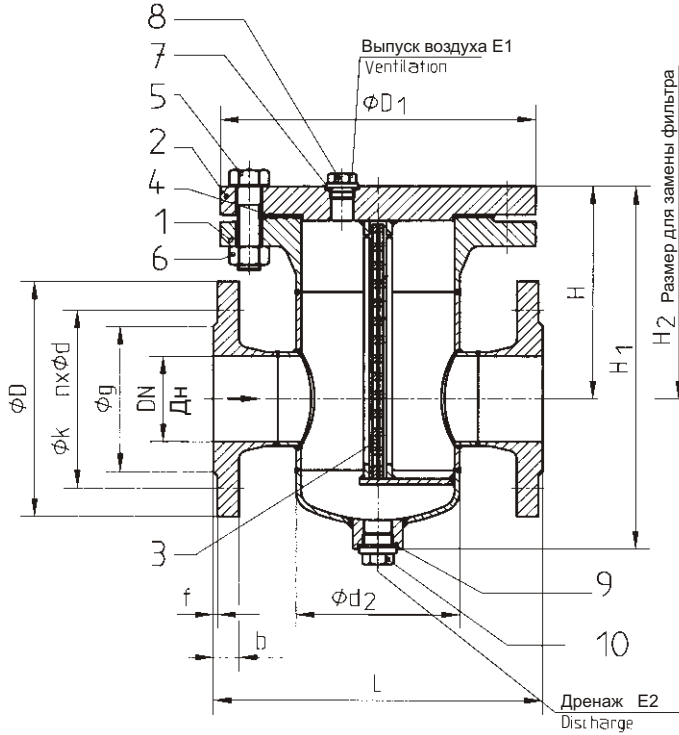

Исполнение начиная с Дн 200
Design from DN 200

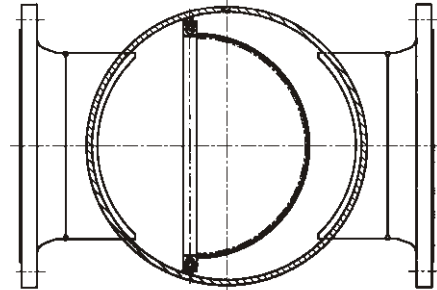
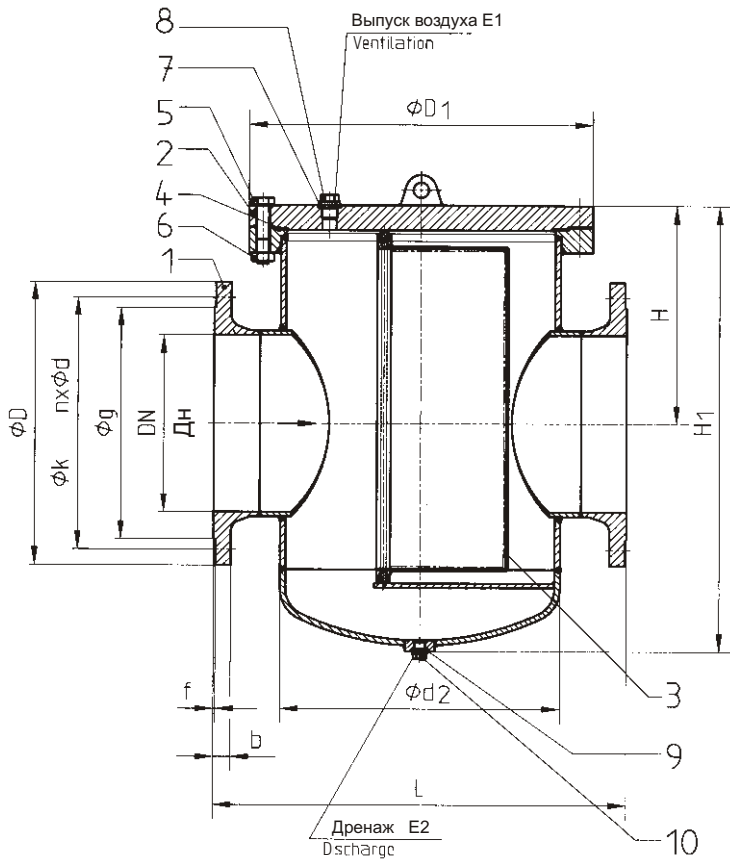



Конструктивные размеры и веса / Structural dimensions and weights

Дн DN	Ру PN	Конструктивные размеры / Installation dimensions							Размеры фланцев/Flange connection dimensions						Вес [кг] Weight [kg]	
		L	D1	d2	H	H1	H2	E1	E2	D	k	nxd	g	b		f
50	6	230	210	114,3	150	240	330	G 3/8	G 1/2	140	110	4x14	90	14	3	20
	10		220		150	255	325			165	125	4x18	102	18	3	21
	16		220		150	255	325			165	125	4x18	102	18	3	21
	25		235		155	270	330			165	125	4x18	102	20	3	26
	40		235		155	270	330			165	125	4x18	102	20	3	26
65	6	290	240	139,7	170	300	380	G 3/8	G 1/2	160	130	4x14	110	14	3	28
	10		250		170	300	385			185	145	4x18	122	18	3	30
	16		250		170	300	385			185	145	4x18	122	18	3	30
	25		270		175	300	385			185	145	8x18	122	22	3	36
	40		270		175	300	385			185	145	8x18	122	22	3	36
80	6	310	265	168,3	180	335	430	G 3/8	G 1/2	190	150	4x18	128	16	3	33
	10		285		180	335	430			200	160	8x18	138	20	3	36
	16		285		180	335	430			200	160	8x18	138	20	3	36
	25		300		185	340	445			200	160	8x18	138	24	3	41
	40		300		185	340	445			200	160	8x18	138	24	3	41
100	6	350	295	193,7	200	380	485	G 3/8	G 1/2	210	170	4x18	148	16	3	48
	10		315		200	380	485			220	180	8x18	158	20	3	50
	16		315		200	380	485			220	180	8x18	158	20	3	50
	25		330		225	390	510			235	190	8x22	162	24	3	63
	40		350		225	390	510			235	190	8x22	162	24	3	63
125	6	400	320	219,1	220	475	600	G 3/8	G 1/2	240	200	8x18	178	18	3	60
	10		340		220	475	600			250	210	8x18	188	22	3	63
	16		340		220	475	600			250	210	8x18	188	22	3	63
	25		360		245	490	630			270	220	8x26	188	26	3	87
	40		375		245	490	630			270	220	8x26	188	26	3	87
150	6	480	375	273	270	545	700	G 1/2	G 3/4	265	225	8x18	202	18	3	94
	10		395		275	550	715			285	240	8x22	212	22	3	97
	16		405		275	550	715			285	240	8x22	212	22	3	97
	25		425		280	570	730			300	250	8x26	218	28	3	153
	40		450		280	570	730			300	250	8x26	218	28	3	153
200	6	600	440	323,9	320	565	755	G 1/2	G 3/4	320	280	8x18	258	20	3	117
	10		445		325	570	760			340	295	8x22	268	24	3	121
	16		460		320	560	760			340	295	12x22	268	24	3	138
	25		485		326	570	760			360	310	12x26	278	30	3	169
	40		515		335	605	785			375	320	12x30	285	34	3	208
250	6	600	490	355,6	355	695	900	G 1/2	G 1	375	335	12x18	312	22	3	170
	10		505		360	700	910			395	350	12x22	320	26	3	175
	16		520		335	700	900			405	355	12x26	320	26	3	190
	25		475		355	720	910			425	370	12x30	335	32	3	223
	40		500		370	750	950			450	385	12x33	345	38	3	275
300	6	700	540	406,4	370	815	1090	G 1/2	G 1	440	395	12x22	365	22	4	210
	10		565		375	820	1100			445	400	12x22	370	26	4	220
	16		580		380	830	1050			460	410	12x26	378	28	4	231
	25		525		415	820	1100			485	430	16x30	395	34	4	310
	40		525		415	820	1100			515	450	16x33	410	42	4	410
350	6	800	610	508	405	910	1140	G 1/2	G 1 1/2	490	445	12x22	415	22	4	310
	10		620		410	915	1150			505	460	16x22	430	26	4	340
	16		630		420	930	1170			520	470	16x26	438	30	4	410
	25		640		460	970	1220			555	490	16x33	450	38	4	440
	40		660		470	990	1250			580	510	16x36	465	46	4	700
400	6	900	710	610	420	900	1200	G 1/2	G 1 1/2	540	495	16x22	465	22	4	318
	10		720		425	905	1200			565	515	16x26	482	26	4	360
	16		730		440	920	1200			580	525	16x30	490	32	4	460
	25		750		480	965	1250			620	550	16x36	505	40	4	590
	40		770		520	970	1250			660	585	16x39	535	50	4	790
500	6	1100	800	700	510	1220	1550	G 1/2	G 1 1/2	645	600	20x22	570	24	4	646
	10		810		515	1225	1550			670	620	20x26	585	28	4	690
	16		820		525	1235	1550			715	650	20x33	610	34	4	850
	25		860		535	1250	1550			730	660	20x36	615	44	4	1040
	40		870		535	1275	1580			755	670	20x42	615	52	4	1170
600	6	1300	920	800	635	1485	1900	G 3/4	G 1 1/2	755	705	20x26	670	24	5	945
	10		930		640	1490	1900			780	725	20x30	685	28	5	960
	16		930		650	1510	1900			840	770	20x36	725	36	5	1190
	25		960		650	1510	1900			845	770	20x39	720	46	5	1450
	40		970		720	1550	1950			890	795	20x48	735	60	5	1830

Материал / Materials

Поз./Item	Наименование	Designation	SF 341 - SF 345		SF 346 - SF 348	
			Материал / Material	М.-№/М.-No.	Материал / Material	М.-№/М.-No.
1	Корпус	Body	P235G1TH (ст.35.8) C22G2 (C22.8) P265GH (HII)	1.0305 1.0460 1.0425	X6CrNiMoTi17-12-2	1.4571
2	Крышка	Cover	P265GH (HII)	1.0425	X6CrNiMoTi17-12-2	1.4571
3.1	Опорная рама	Perforated plate	S235JRG2 (RSt 37-2)	1.0038	X6CrNiMoTi17-12-2	1.4571
3.2	Сетка	Wire cloth	X4CrNiMo17-12-2	1.4401	X4CrNiMo17-12-2	1.4401
4	Уплотнение	Sealing	без асбеста / Asbestos free	-	без асбеста / Asbestos free	-
5	Болт	Hex-head screw	5.6	-	A4-70	-
6	Гайка шестигранная	Hex-nut	5-2	-	A4	-
7	Уплотнение	Sealing	без асбеста / Asbestos free	-	без асбеста / Asbestos free	-
8	Пробка	Plug	5.6	-	A4-70	-
9	Уплотнение	Sealing	без асбеста / Asbestos free	-	без асбеста / Asbestos free	-
10	Пробка	Plug	5.6	-	A4-70	-



Исполнение с быстрозапорной крышкой, откидным устройством и показателем потери давления
Design with quick acting cover, swing device and differential pressure indicator

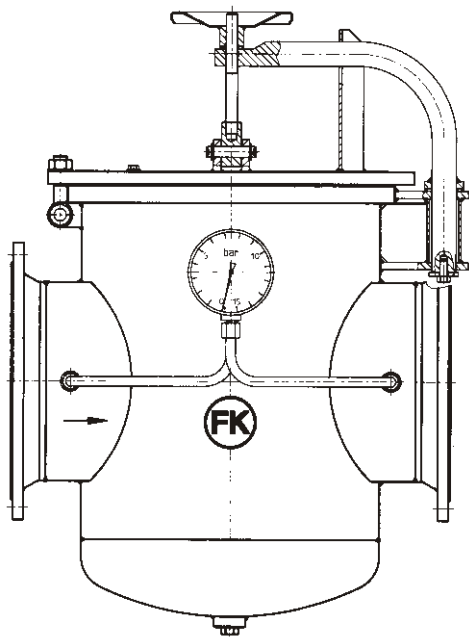

Исполнение с обогреваемой рубашкой
Design with heating jacket

Вход обогревающей среды
(сзади)
Steam exhaust backward

Выход обогревающей среды
(спереди)
Steam inlet forward

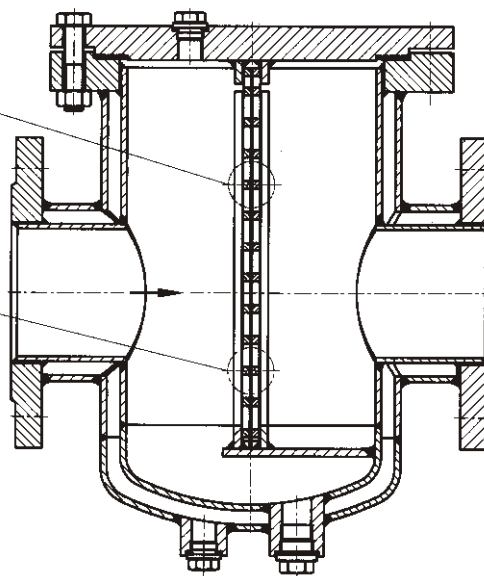

Рабочие и пробные давления для воды / Working and control pressure

№-заказа Order-No.	пробное давление в корпусе, bar Water-control pressure [bar] body		max. рабочее давление, bar Max. working pressure in bar						
	Py / PN	bar	20°C	50°C	120°C	150°C	200°C	250°C	300°C
SF 341	6	9	6	6	6	6	5	4,5	3,6
SF 342	10	15	10	10	10	9	8	7	6
SF 343	16	24	16	16	16	15	14	13	11
SF 344	25	38	25	25	25	23	22	20	17
SF 345	40	60	40	40	40	37	35	32	28
SF 346	10	15	10	10	9,5	9,1	8,5	8,1	7,8
SF 347	16	24	16	16	15,2	14,6	13,7	13	12,4
SF 348	25	38	25	25	23,8	22,8	21,3	20,3	19,4

Дн / DN	50	65	80	100	125	150	200	250	300	400	500	600
Коэф. сопротивл. (Z)	3,1	3,1	3,2	3,2	3,4	3,5	3,5	3,5	3,6	3,5	3,5	3,2
Коэф. расхода (Kv), м3/h	57	96	143	223	338	480	854	1334	1895	3417	5338	8040

Мах. допускаемые гидравлические потери на грязеуловителе 2 bar, мах. скорость среды 2,5 м/сек. (для воды)
The max. allowed differential pressure is 2 bar. The max. allowed flow rate is 2,5 m/s (water).

Специальные исполнения:

- другие размеры ячеек сетки
- с опорной конструкцией
- с дырчатым фильтром
- другие материалы

Available special designs:

- With other mesh
- With stanchion
- Further nominal widths on request
- Other materials

Указанная арматура соответствует по конструкции, габаритам, весу и применённым материалам современному состоянию техники и в дальнейшем может быть изменена. За возможные опечатки или ошибки перевода мы ответственности не несём.
The construction, the measurements and the weights of the described valves represent the current technical standards. We reserve the right to change the technical details and to use materials of equivalent and higher quality. We accept no warranty for any printing or translation errors that might be found in this catalogue.